



WP345 Ford Modular High Flow Pump (Page 1 of 3)

In The Box:

- 1 Electric Water Pump WP345
- 4 8mm x 25mm SSHCS and washers
- 1 Wiring harness w/ 20 amp fuse
- 2 Contingency decals

To do the job, you will need:

- Tie wraps
- Scraper or wire brush
- Brake cleaner
- Light grease
- Thread locking compound
- Metric allen wrench set
- Metric socket set
- **Vacuum assist coolant filler**



NOTE: The WP345 pump model will be well suited to highly modified engine packages which may or may not incorporate the stock accessories. The pump does not have an idler so if you are using a serpentine belt it will need to be re-routed. The following instructions may not apply to your exact situation. If you need assistance please call and we will be happy to assist you.

Removing the stock pump:

1. Drain coolant. (when the engine has cooled)
2. Loosen all four bolts on the water pump pulley.
3. Use ratchet or pry bar to release the belt tension and remove the drive belt from the water pump pulley.
4. Remove four drive flange bolts and the water pump pulley.
5. Remove four mounting bolts and the water pump.
6. Clean the face and bore of the water pump mating area.

Mounting the Pump:

1. Lubricate the o-ring.
2. Align the Meziere water pump with the bolt pattern in the block and push into place. Bolt the pump in place using the supplies stainless hardware and snug evenly. Use a small amount of thread locking compound on the mounting bolts. Tighten all four to 18 Ft.-Lbs.
3. Route the wires away from any rotating parts or pinch areas and use zip-ties to secure.
4. Reinstall the drive belt if applicable.
5. Check to make sure no brackets or other parts will need to be moved or modified as this pump does occupy more space than the original pump.

...go to page 2 please



WP345 (Page 2 of 3)

Wiring the Pump:

The black wire should be routed to ground. The blue wire should be routed to an ignition hot source. If the wire you intend to use as the power source is not large enough to carry the extra current that the pump will demand (11-15 amps) you should consider using a relay. Most applications will require this. Meziere offers a generic wiring kit # WIK346 for this purpose.

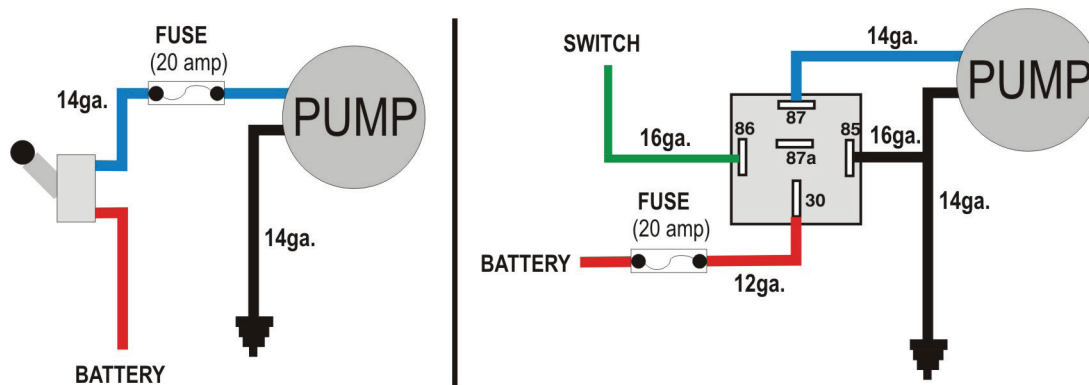

Refilling the System:

To fill the system, Meziere strongly recommends the use of a Vacuum Assist Coolant Filler tool to eliminate air trapping problems. Most shops will have this tool as a standard for working on late model vehicles. In our experience, this particular model can be very difficult to re-fill without this tool. Recheck the fluid level after one heat cycle. **DO NOT RUN THIS PUMP DRY** for more than a few seconds.

Beauty Tip:

Your pump comes to you polished and waxed. Occasional waxing will allow dirt or debris to be wiped right off the pump and offer some protection from UV light (the anodized color on your pump can fade from prolonged exposure to sunlight).

California Proposition 65 Warning: Please see the next page for Prop 65 information.

Thank you for purchasing our product. Feel free to contact us if we can be of further assistance and enjoy your pump.

WARNING: RUNNING THE PUMP WITHOUT THE FUSED CIRCUIT WILL VOID YOUR WARRANTY.

Meziere Enterprises 220 S. Hale Ave. Escondido, CA 92029 760-746-3273



WP345 (Page 3 of 3)

California Proposition 65 Warning

WARNING: This product contains chemicals known to the State of California to cause cancer and birth defects or other reproductive harm.

WARNING: Motor vehicles contain fuel, oils and fluids, battery posts, terminals and related accessories which contain lead and lead compounds and other chemicals known to the State of California to cause cancer, birth defects and other reproductive harm. These chemicals are found in vehicles, vehicle parts and accessories, both new and as replacements. When being serviced, these vehicles generate used oil, waste fluids, grease, fumes and particulates, all known to the State of California to cause cancer, birth defects, and reproductive harm.

For background on the new Proposition 65 warnings, see:
<https://www.p65warnings.ca.gov/new-proposition-65-warnings>

Proposition 65 and its regulations are posted at:
<https://oehha.ca.gov/proposition-65/law/proposition-65-law-and-regulations>

To give Meziere notice of an alleged violation of California Health and Safety Code Section 25249.5 or 25249.6, you must send notice to:
meziere@meziere.com