

Application Note: TST409 is designed for big block Ford applications. It is compatible ONLY with ten pitch ring gears, usually our 140 tooth count ring gear.

True Start Performance Starter Installation Instructions

Caution:

Starter replacement often requires working under a vehicle handling heavy components. Always be sure to use proper safety precautions and safety jack stands on a level surface to support the vehicle. Failure to follow these precautions could result in serious personal injury!

Recommended Tools To Do the Job:

- Appropriate hand tools to remove and replace fasteners
- Electrical supplies and terminating tools
- Voltmeter (if diagnosing the starting system)

Removing the Old Starter - Looking for Problems:

If you are replacing an existing starter which has failed, pay careful attention to the mode of failure and look for any mechanical / electrical problems somewhere else in your assembly which could be corrected to avoid the problem happening again. Common problems are mechanical misalignments, starter system problems, engine tune-up problems, fastener problems, and problems with interferences.

While removing your old starter, pay attention for fasteners which may have been damaged or loose. Also look for any cracks, metal transfer, or abnormal ring gear wear which may suggest other problems. Special care to remedy problems at this point can avoid repeat failures.

Installing the True Start Starter / Checking for Fit:

Thoroughly clean the engine starter mounting surface of any rust, dirt or paint. This is important. The Meziere True Start nose block has special features to provide additional starter rigidity, but mating surface cleanliness is important. Make a test fit with the True Start Starter. There must be some clearance to the engine oil pan, chassis, exhaust, etc. The starter assembly itself may be rotated in relation to the starter nose in very fine increments to achieve clearance. When reinstalling the nose block, torque bolts to 70 inch pounds, use lock washers and thread locking compound.

Checking Ring Gear to Pinion Clearance / Fit: The drive gear has 3/8-16 internal threads to aid in engaging the drive gear to the ring gear. Screw a bolt in and use pliers to pull the drive gear out.

This is vital to starter operation and starter / ring gear life. Once the starter is mounted in position, check to make sure that the starter pinion has adequate clearance from the ring gear. Our recommended distance is .100 +/- .04 (see Figure 1). Next, engage the starter pinion by jogg the starter or manually pulling the pinion gear out. Check to make sure there is some backlash clearance (.010"-.030" recommended, see Figure 2) between the gears when engaged. Double check that the drive gear is not bottomed out into flexplate ring gear. Also, be sure there is not excessive clearance. The standard Ford design does not provide adjustment in this direction. Fortunately, you have purchased the TST409 model. The following page will detail the procedure for adjusting the pinion clearance in the radial direction. **In all cases, make sure all vehicle electrical power is disconnected whenever your body parts are in and around the pinion / ring gear area!**

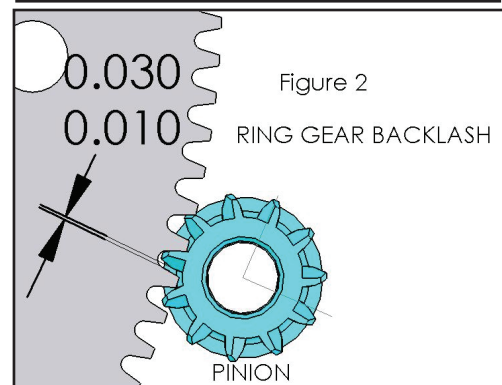
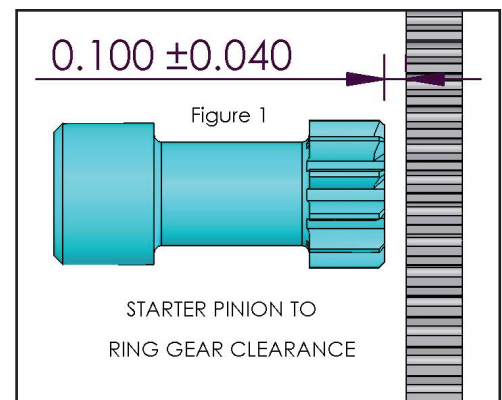

California Proposition 65 Warning: Please see page 4 for Prop 65 information.

True Start Performance Starter Installation Instructions TST409 addendum for eccentric radial adjustment

The radial adjustment (distance to crankshaft centerline) should be done after the starter has been trial fitted, the desired solenoid rotation has been achieved and the proper axial clearance (front to back) has been accomplished. The starter is shipped with the eccentric feature adjusted to the position which is furthest away from the crankshaft centerline. That position is the closest to the stock Ford starter configuration. Install the starter and observe radial clearance. The starter will work best with the recommended .010 to .030 backlash indicated in the illustration on page 2. If the clearance is observed to be too tight that is an indication of a problem with the position of the mounting holes. Our nose will not cure that problem. If the clearance is observed to be too great, the eccentric feature will help to correct that.

Step 1: Try to determine the actual clearance and how much adjustment will be necessary to bring the lash into the correct range.

Step 2: Remove the starter and set on a bench with the pinion or mounting end of the starter facing up.

Step 3: Taking note of the small roll pin (clocking pin) and its location relative to the front plate (the main mount plate with three large holes) remove the two smaller screws located closest to the center bearing.

Step 4: Lift the center plate straight up off of the front plate. To separate the nose assembly from the starter it may be necessary to tap on the starter drive gear with a plastic hammer while lifting on the nose assembly. Rotate the center plate one (1) position for every .010 lash adjustment required (ex.: if .020" adjustment is necessary, move the pin 2 positions in the clockwise direction). Set the center plate back down over the pinion and mate the parts with no misalignment, making sure that the clocking pin is inside of the desired receiver hole.

Step 5: Looking down through the center plate, identify the 2 best spots for the 1/4" bolts to be reinstalled. The goal is to keep the overall clocking of the solenoid as close to its original position as possible, as this is the position you have already set for best clearance on your vehicle. You may need to rotate the main body slightly in one direction or the other to line up the holes in the center plate with the holes in the main housing. Install the two 6MM bolts with locking washers and torque to 100-120 inch pounds.

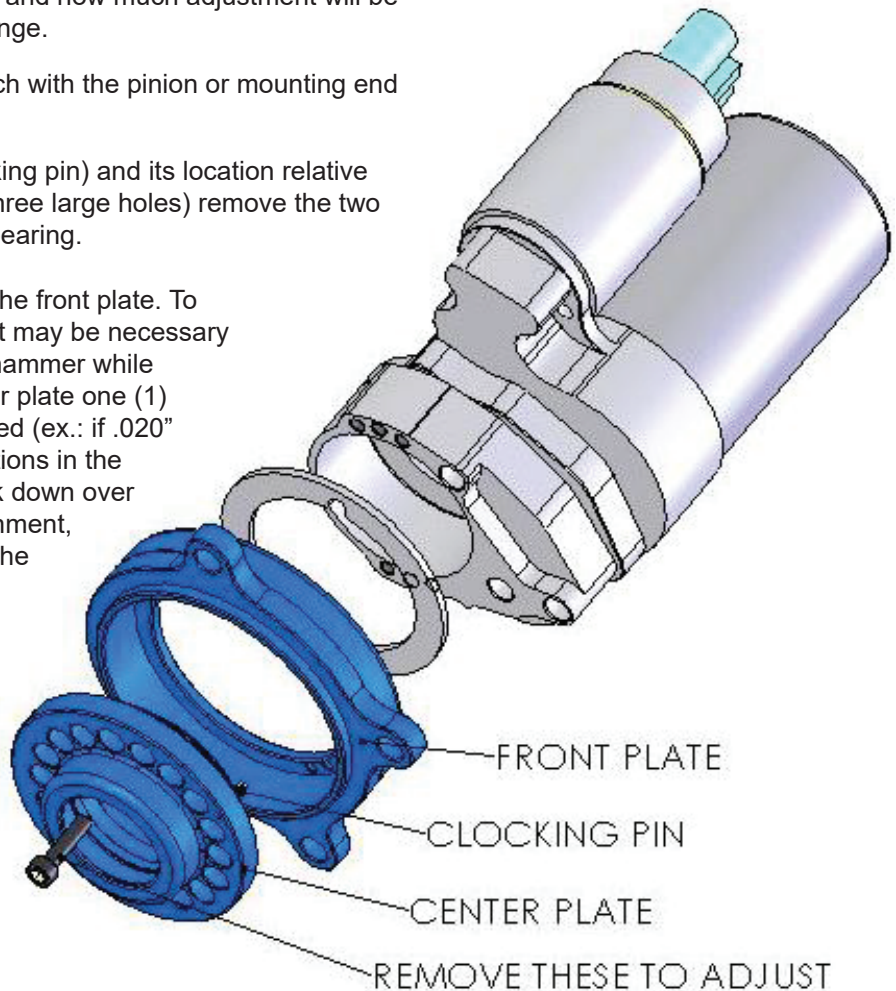

Step 6: Install the starter and check final clearances. If more adjustment is necessary repeat steps 1 through 6.

California Proposition 65 Warning: Please see page 4 for California Prop 65 information.

Meziere Enterprises 220 S. Hale Ave. Escondido, CA 92029 760-746-3273



True Start Performance Starter Electrical and Engine Tune Troubleshooting

Proper performance of your new starter will be enhanced if you take the time to inspect some of the systems around the starter. The following is a good list of things to check:

Starter Electrical Circuit:

The main battery cable for the starter power needs to be attached to the largest solenoid terminal (10MM Dia.). This terminal is larger than most performance starters for better cable anchoring and current switching capability. The starter switch hot wire attaches to the spade terminal on the solenoid. These are the only two connections necessary. Note: Your starter switch should be capable of switching 50A of 12VDC power. The solenoid wire should be at least 10AWG. The solenoid can require as much as 40 amps of current to function properly during an average starting cycle. Sizing your switch/ solenoid wire properly at this time can avoid a hot starting problem!

Warning: If you are connecting this starter to any power source that will deliver more than 17 volts to either connection point, contact Meziere Enterprises' tech department for additional support.

See page 4 for recommended start circuit wiring.

Battery Power:

Your starter cannot perform to its potential if it does not get proper voltage and current. A quick check can make sure your starter wiring is correct. For this test disable the engine from possibility to start.

Measure voltage at the vehicle battery while cranking. Next measure voltage at the starter terminal while cranking. The voltage at the starter should be within 1 volt of the reading at the battery. At any time the voltage at the starter should not be less than 10.0VDC. If an excessive voltage drop exists, measure voltages at each connection in the system and repair the system as necessary. An under-voltage starter can cause excessive load on the starter as well as overload to the starter gear and ring gear.

Fuel System / Engine Tune Up:

An improperly functioning fuel or ignition system, and/or a bad starting sequence by the driver can cause extreme overloads to the starter gear and ring gear. This problem is amplified as displacement and compression ratios are increased. Here are a few simple things to look for and think about:

Make sure your fuel system is not leaking raw fuel down into cylinders prior to starting. Always allow the engine to complete a few rotations **without** ignition prior to starting. A cylinder loaded with fuel is almost sure to kick back and severely overload your starting system components if ignition is applied. Make sure also that your ignition system has a start retard function to back timing down as far as possible for starting. This will greatly decrease the starter gear/ ring gear load.

Maintenance: Periodically check electrical connection for loosening or corrosion. Avoid getting the starter wet as with any electrical component! Long periods of cranking will damage the starter. Increased voltages will also increase starter wear.

Note: Starter drive may stay engaged if the engine does not start. This is normal. When the engine RPM is above starter rpm the starter will disengage. Do not manually turn the engine backwards during this condition. Damage may occur.

No Warranty: No warranty is expressed or implied. Because of the nature of this application Meziere limits responsibility to quality and workmanship **before** installation. We are not liable for any consequential damage during use or installation.

Congratulations on choosing the Meziere Enterprises TST409 True Start Starter. Meziere has again raised the bar in high performance starters. Here are some of the features about this product you should know:

- Maximum off set design provides 3 HP with a killer 3.1 to 1 gear reduction.
- A Clean Sheet – Every component constructed with performance in mind.
- High strength alloys incorporated throughout for uncompromised strength.
- Ball and needle bearings used throughout for long-lasting, reduced friction and precision operation.
- Oversized solenoid for powerful bendix engagement and incomparable electrical operation.
- Specially modified, balanced, and potted armature for dependable smooth operation, even at increased voltages.
- Precision – CNC machining incorporated throughout for product exactness and repeatability.
- Quality – Each unit tested to guarantee the highest performance standards before our name goes on it.
- Meziere tech support – Competent sales/product support to answer your questions and make our product a success for you!



RECOMMENDED WIRING FOR OUR TS400 AND TS500 SERIES STARTERS

To our valued customers: We strive to make sure you are well satisfied with the purchase of your Meziere product. Please note, many cars are not wired to support the demands of our starter and solenoid combination. If your vehicle is not starting correctly, please refer to this schematic. It may save a lot of time and disappointment.

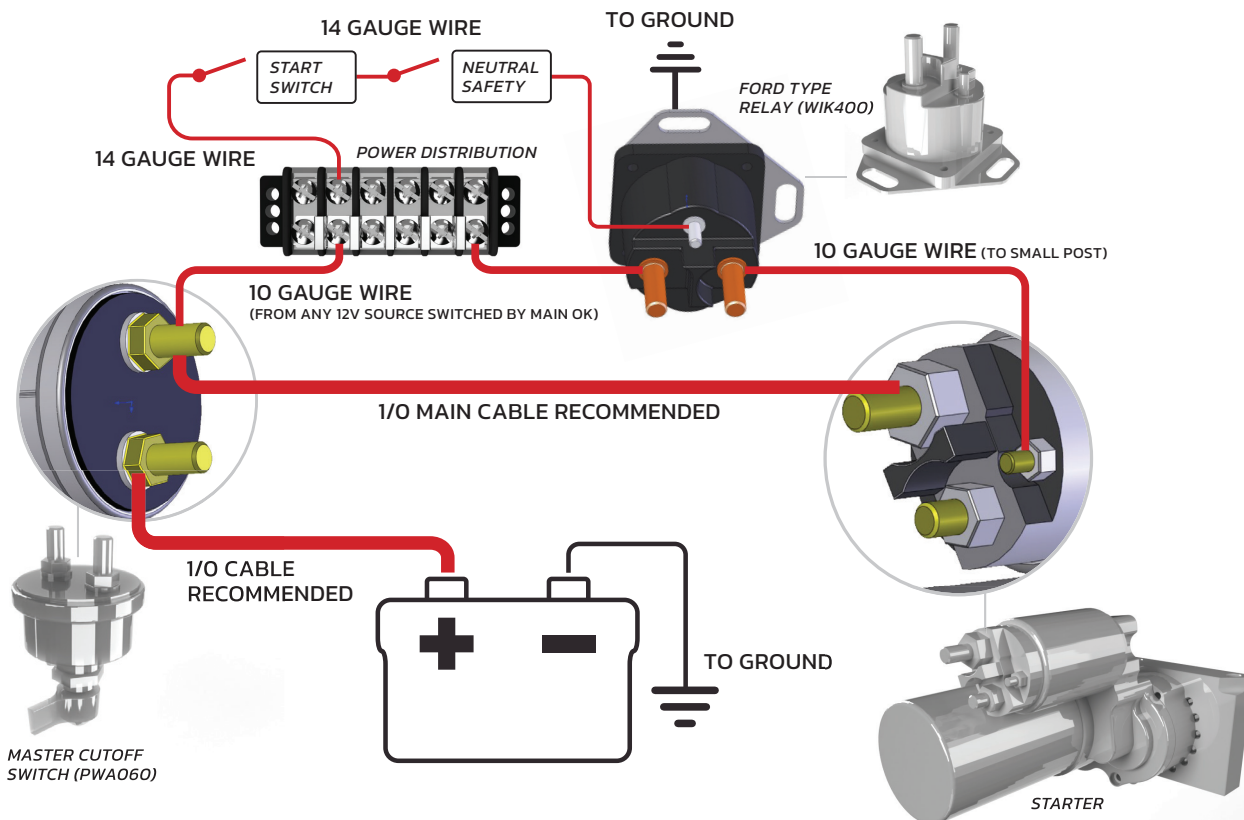

California Proposition 65 Warning

WARNING: This product contains chemicals known to the State of California to cause cancer and birth defects or other reproductive harm.

WARNING: Motor vehicles contain fuel, oils and fluids, battery posts, terminals and related accessories which contain lead and lead compounds and other chemicals known to the State of California to cause cancer, birth defects and other reproductive harm. These chemicals are found in vehicles, vehicle parts and accessories, both new and as replacements. When being serviced, these vehicles generate used oil, waste fluids, grease, fumes and particulates, all known to the State of California to cause cancer, birth defects, and reproductive harm.

For background on the new Proposition 65 warnings, see:
<https://www.p65warnings.ca.gov/new-proposition-65-warnings>

Proposition 65 and its regulations are posted at:
<https://oehha.ca.gov/proposition-65/law/proposition-65-law-and-regulations>

To give Meziere notice of an alleged violation of California Health and Safety Code Section 25249.5 or 25249.6, you must send notice to:
meziere@meziere.com