

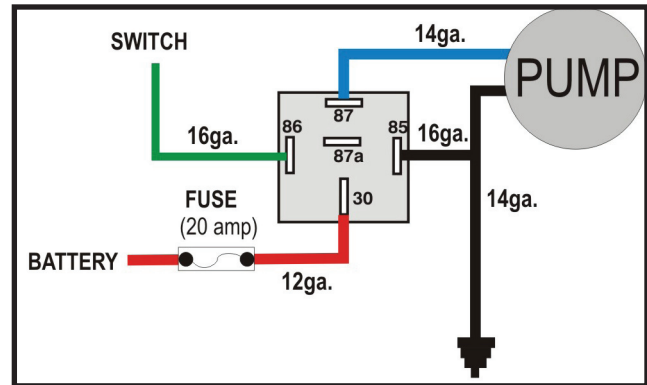

WIK329 Wiring Installation Kit

In The Box:

- 1 Instruction sheet
- 1 30 Amp relay
- 1 Harness with 20A and 2A fuses
- 1 Fuse Tap
- 2 1/4-20 SHCS 7/8" long
- 2 1/4-20 Locking nuts
- 1 1/4" Star washer



Wiring for Chevrolet Camaro applications:

Attach the relay to an open 1/4" hole on the front passenger side of the factory fuse box. Drill a 1/4" hole through the metal fender support and attach the ground wires (black) using the supplied star washer. Remove the fuse from the ignition source found in the fuse box and place the factory fuse into the bottom fuse location on the Fuse Tap. Place the 2 Amp fuse in the top location on the Fuse Tap (if not already installed). Connect the red power wire to the power post located just in front of the factory fuse box. Connect the weather pack connector to the electric water pump. Clearance the fuse box lid to accommodate the wires exiting the box.

For additional information, see the Meziere YouTube page at:

[YOUTUBE.COM\USER\MEZIEREENTERPRISES](https://www.youtube.com/user/MEZIEREENTERPRISES)

Thank you for purchasing the WIK329 wiring kit. Please contact us if there are any questions regarding this product.